

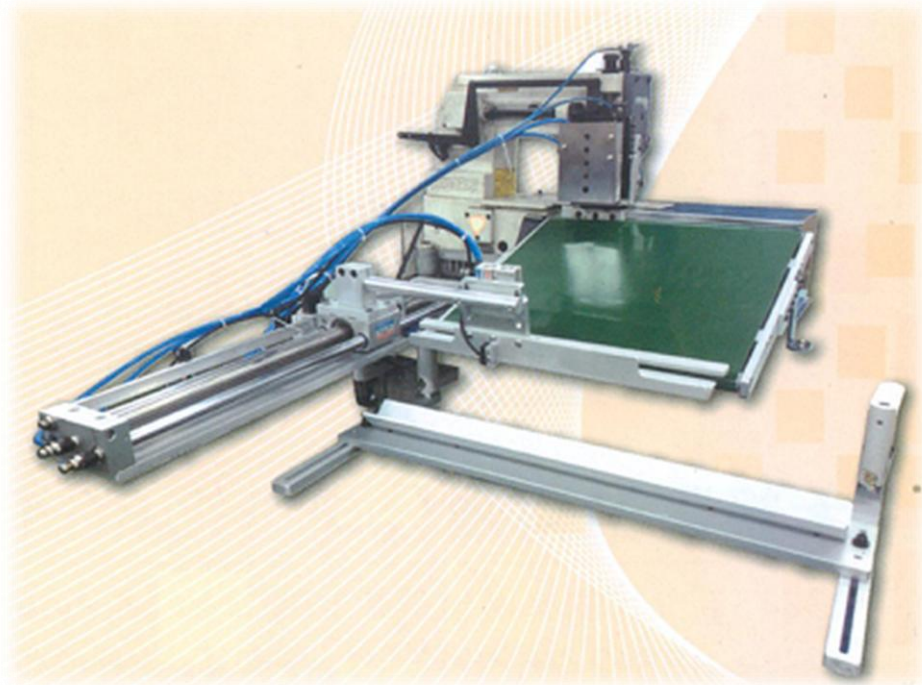

# HST-M 自動收衫機安裝手冊

## THE INSTRUCTION GUIDE BOOK FOR AUTOMATIC MATERIAL RECEIVING MACHINE



安裝前,請詳細閱讀安裝說明書

PLEASE READ INSTRUCTIONS & ASSOCIATED DRAWINGS BEFORE INSTALLATION

# HST-M

## 自動收衫機安裝說明 Automatic Stacker Machine installation

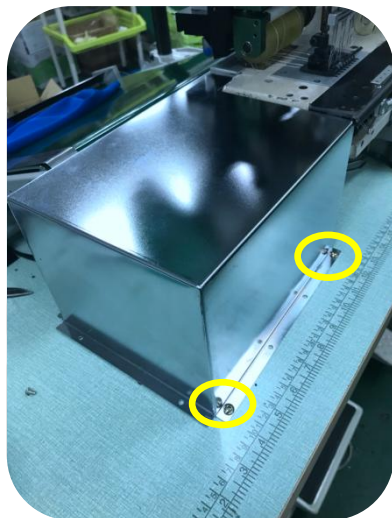

1. 安裝鐵台  
To install the platform



2. 安裝輸送帶  
To install the conveyor belts



3. 鎖上滑軌  
To install the rails

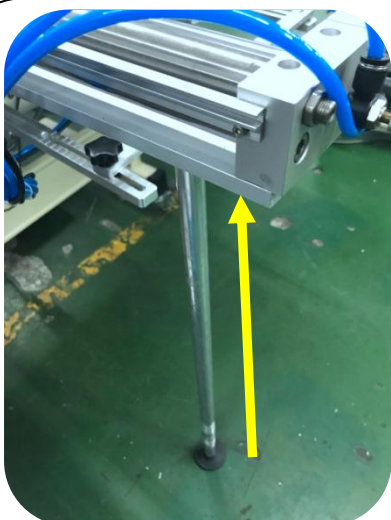

4. 鎖上滑軌支撐架  
To lock the fixing frame  
of rails

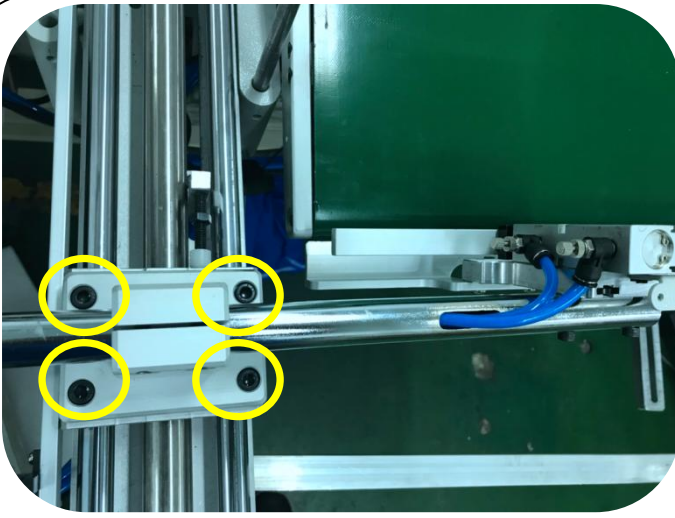

5. 鎖上夾子  
To lock the clip

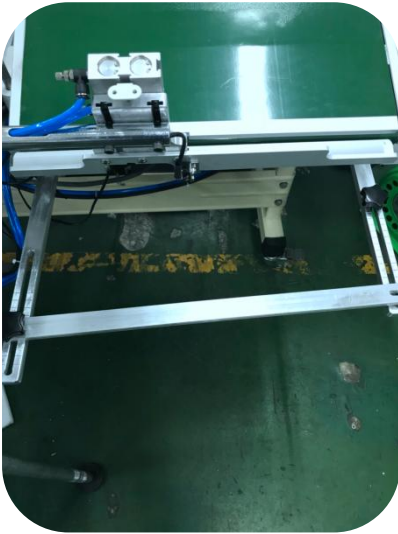

6. 安裝收料區(可調整高度)  
To install the receiving area (adjustable height)



7. 固定控制箱  
To fixing the control box

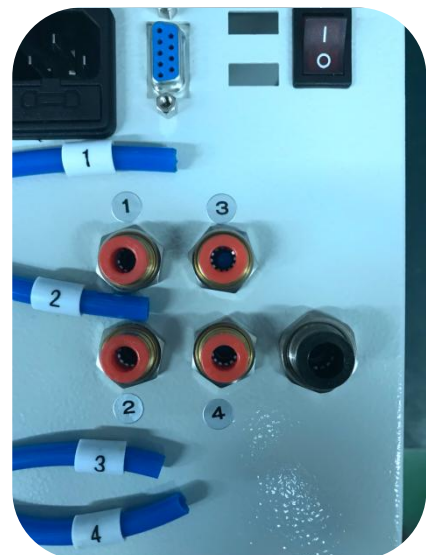

8. 依照數字接上風管  
Connect the air duct according to the number

# HST-M 軟體說明 Software description

D201

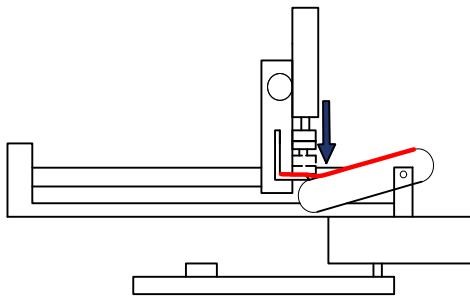

D202

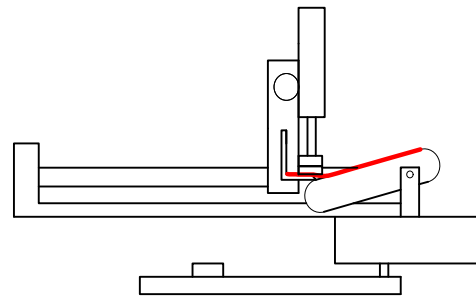

D201：確認布料時間。To confirm cloth time

D202：確認夾取時間。To confirm gripping time

D203

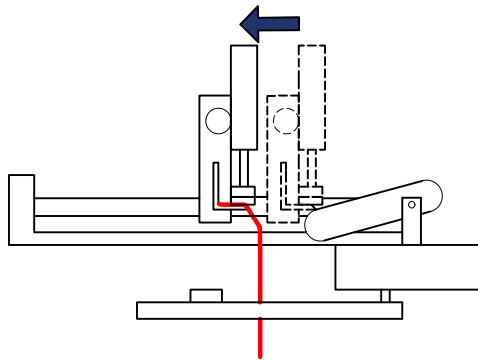

D204

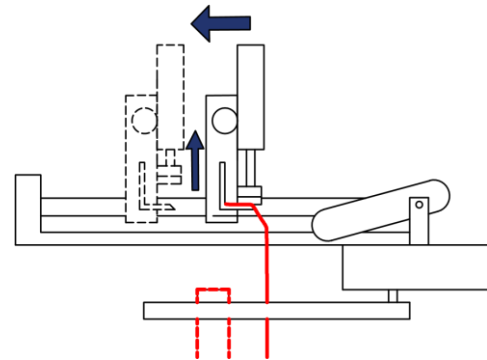

D203：第一段後退的持續時間。The duration of the first paragraph retreat

D204：第二段後退的啓動時間。The start time of the second paragraph retreat

D205 D206=0

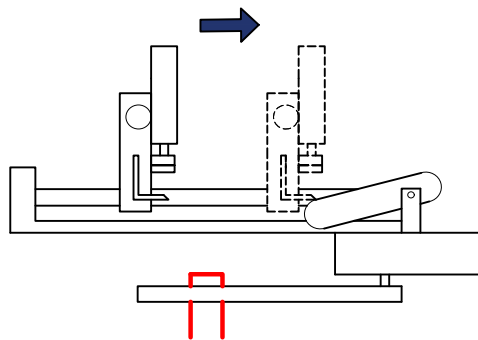

D206≠0

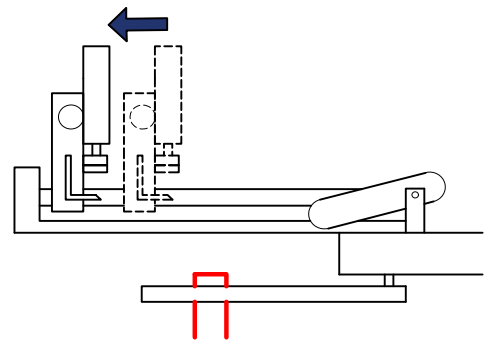

D205：第三段位移的啓動時間，D206=0 時返回原點。

The start time of the third paragraph displacement, return to the origin when D206=0.

D206≠0：第三段後退的持續時間，時間結束後返回原點。

The duration of the third paragraph retreat, return to the origin after the time is over.

※：D200，D209 為系統預設值，請勿更改。

※：D200, D209 are system preset values, please do not change.